

5RZ46



 MADE IN ITALY 

PLACING BOOM:
OPENING SYSTEM "RZ"

PUMPING UNIT:
UP TO 194 m³/h

TOTAL WEIGHT:
< 32 t (70547 lb)

ASSEMBLY ON VEHICLE 4 AXLES:
**WB 4,850 – 5,450 mm
(15'10" - 17'10")**

TECHNICAL CHARACTERISTICS



- Concrete pump produced, assembled and tested by SERMAC
- Structural integrity verified with the Finite Element Method (FEM)
- Pump frame designed for high torsion rigidity
- Suitable for assembly on 4-axle trucks
- Boom 5-stage, RZ-folding type
- Pipeline diameter 125 mm (5")
- Main components sourced from genuine German and Italian manufacturers
- Pumping unit with open hydraulic system and high manganese cast iron S-valve
- Ideal for working in tight spaces



5RZ46



NO WORKING AREA

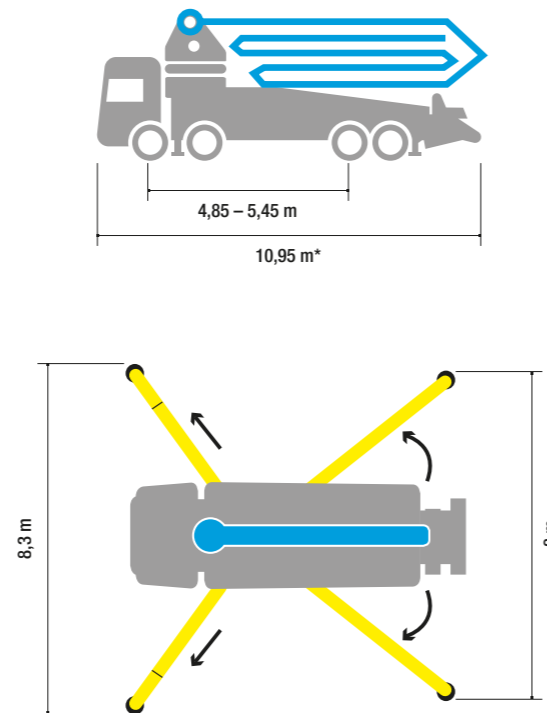
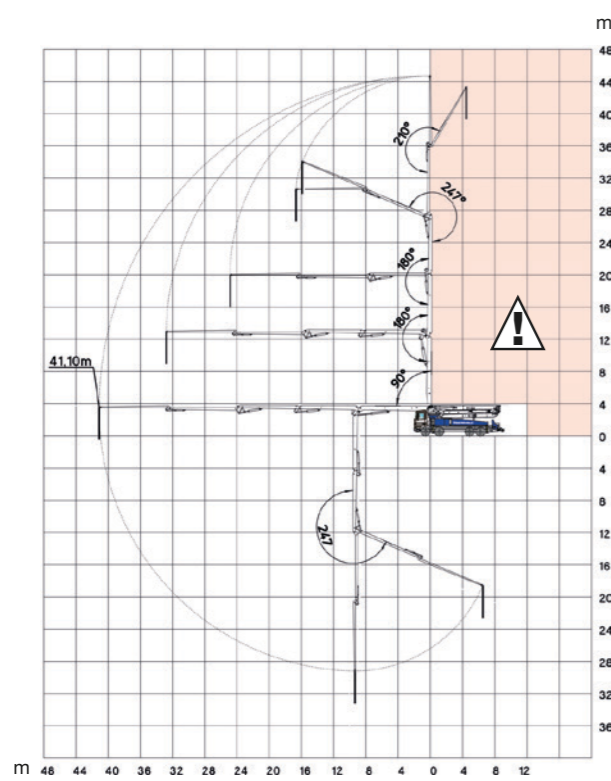

*Dimensions variable according to the truck assembly

DISTRIBUTION BOOMS

MAX. VERTICAL REACH	45,1 m (147'11")
MAX. HORIZONTAL REACH	41,1 m (134'10")
MAX. DOWNWARD REACH	-33,1 m (-108'7")
NUMBER OF BOOM SECTIONS	5
MIN. UNFOLDING HEIGHT	9,1 m (29'10")
BOOM ROTATION	370°
BOOM SECTION ARTICULATION	90° - 180° - 180° - 247° - 210°
BOOM UNFOLDING SYSTEM	RZ
FRONT OUTRIGGERS	Telescopic "X"
REAR OUTRIGGERS	Swing-out
FRONT OUTRIGGER SPAN	8,3 m (27'2")
REAR OUTRIGGER SPAN	8 m (26'2")

STANDARD EQUIPMENT

- X-type front outriggers and swing-out type rear outriggers
- Straight pipes made in twin-wall with highly abrasion resistant induction hardened inner liner. Elbows made in twin-wall with chromium carbide inner liner
- Two sets of radio remote controls provided with 2-speed proportional boom control, automatic free frequency search, 8-position joysticks and concrete output control
- Wear compensation system between wear plate and wear ring. Wear plate and wear ring with tungsten carbide inserts.
- Automatic hopper greasing unit with manual back-up system
- Automatic oil lubrication for piston rams
- Safety device on hopper door and hopper grate
- Electric vibrator on hopper grate
- Hydraulic powered diaphragm water pump (75 l/min - 30 bar)
- Water tank capacity 900 l
- Work light on hopper
- Metal bin for accessories beside hopper
- Warning horn on the boom
- Accessories for cleaning and maintenance

PUMPING UNIT

	S8		G9	
	AS8L09-150-76	AG9L09-100-85	AG9L10-158-80	AG9L10-194-80
THEORETICAL OUTPUT (MAX)* ROD SIDE	150 m³/h - 196 yd³/h	-	-	-
THEORETICAL OUTPUT (MAX)* PISTON SIDE	-	100 m³/h - 130 yd³/h	158 m³/h - 206 yd³/h	194 m³/h - 253 yd³/h
PRESSURE ON CONCRETE (MAX)* ROD SIDE	76 bar - 1102 psi	-	-	-
PRESSURE ON CONCRETE (MAX)* PISTON SIDE	-	85 bar - 1232 psi	80 bar - 1160 psi	80 bar - 1160 psi
NUMBERS OF CYCLES PER MINUTES	30 '/min	20 '/min	27 '/min	33 '/min
PISTONS DIAMETER	230 mm	230 mm	250 mm	250 mm
CONCRETE CYLINDERS	2000 mm	2000 mm	2000 mm	2000 mm
S-VALVE DIMENSION	8"	9"	9"	9"
CONCRETE HOPPER CAPACITY	600 l	650 l	650 l	650 l

*Cannot be reached simultaneously



ACCESSORIES ON REQUEST

- Additional work light on hopper
- Air compressor for pipeline cleaning (450 l/min)
- Aluminium hopper cover
- Air charged sprayer for concrete release agent (25 l - 8 bar)
- Automatic release of end hose
- Automatic boom greasing system
- Pressure washer with fan-shaped nozzle (17 l/min - 130 bar)
- Stop flow on end hose
- Multi-stage water pump (230 l/min - 40 bar)
- Pipe storage
- Rear camera
- Sermac Control Stability (SCS)



TRUCK MOUNTED PUMPS

12 different pump models with modern front X-type outriggers and provided with booms with different fold configurations from 20m to 65m vertical reach.



MIXER PUMPS

4 models with Z-fold distribution booms from 21m to 33m vertical reach.



TRAILER PUMPS

7 different models in the combined 6" and 8" Series available in high- and low pressure models.



STATIONARY BOOMS

2 stationary boom models with 28m and 33m reach.